

Typ:	Patch panel	13.06.2017
	Patch panel angled, 48xRJ45/u/s, unequipped	REV: 0.1/MSO
Ref:	XBA100.248.x	

Modular patch panel, angled 48xRJ45/u/s, unequipped, 2U

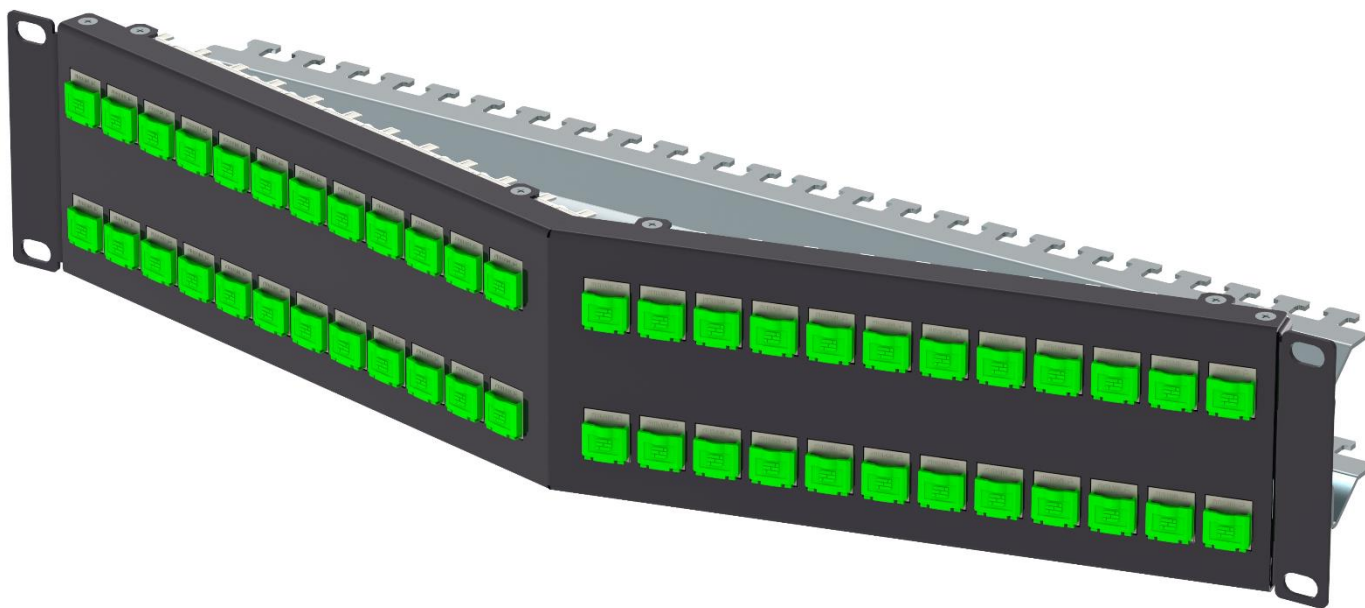

DESCRIPTION:

- 2U/19" montage,
- Modular for keystone type connection modules (shielded/unshielded)
- Integrated cable shelf for cable fixation
- Up to 48 RJ45/u/s ports,
- Angled front plate
- Metal construction enabling galvanic connection of connection modules screens (for shielded version only)
- Large, visible port labeling,
- Color coding by removable dust cover protection

TECHNICAL SPECIFICATION:

Material:

Construction - Steel sheet, tin plated

Weight:

1,2 kg

Scope of supply:

Unequipped frame

Color:

Black: RAL 9005
Grey: RAL 7035.

Operational temperature range:

-40°C do +70°C

Important notice

Buyer and/or user of this product has to make sure before using this product that it is suitable for the intended use. All questions of liability relating to this product are subject – in accordance with the prevailing – to the Term of Sale of the selling Fibrain subsidiary

Typ:	Patch panel	13.06.2017
	Patch panel angled, 48xRJ45/u/s, unequipped	REV: 0.1/MSO
Ref:	XBA100.248.x	

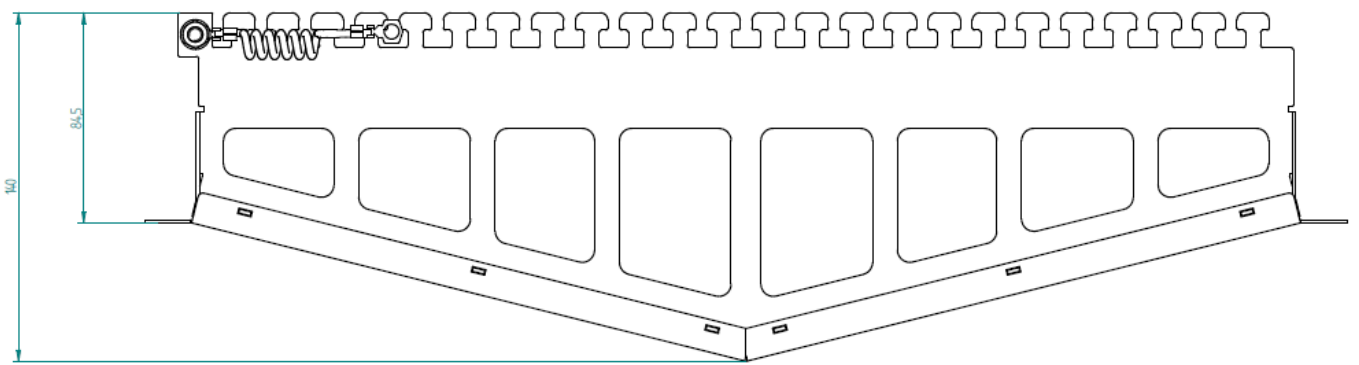
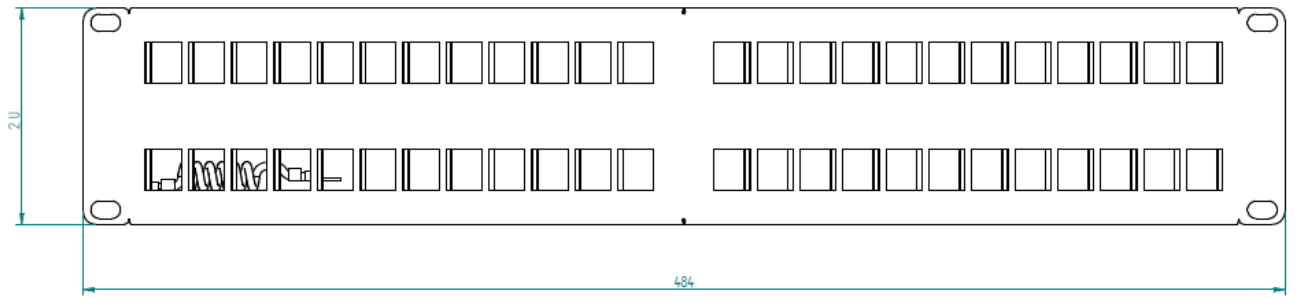

Parameters				Reference number
Height [U = 44,45mm]	Width [mm]	Depth [mm]	Color/RAL	
2U	19"	140	Black/ 9005	XBA100.248.1
2U	19"	140	Grey/ 7035	XBA100.248

Important notice

Buyer and/or user of this product has to make sure before using this product that it is suitable for the intended use. All questions of liability relating to this product are subject – in accordance with the prevailing – to the Term of Sale of the selling Fibrain subsidiary