

FTQ-M4XG-S85L-15MD

QSFP 40GBase-SR4, 850nm, multi-mode, 150m



Description

FTQ-M4XG-S85L-15MD series QSFP+ transceiver can be used to setup a reliable, high speed (up to 40Gbps) serial data link over multi-mode ribbon cable. Maximum link span can reach 150m (over OM4 fiber). This transceiver offer four independent transmit and receive channels. Thanks to module's compact size port density of host device can be archived easily. Casing made fully from metal alloys ensures very good EMI immunity. Module is fully compliant with QSFP+ MSA and IEEE 802.3ba 40GBASE-SR4 specification. MPO connector has built-in two metal pins to ensure proper alignment of fibers.

Host device can access module internal EEPROM memory and DDMI via I2C interface.

Built-in digital diagnostic interface (DOM, DDMI) allows a network administrator to monitor each channel's parameters such as: transmitted and received optical power, temperature, supply voltage and laser current. Those information and data are very helpful e.g. in prediction and prevention of connection failures. A module is available in various dedicated versions, which can be compatible with devices from vendors such as Cisco, HP, Juniper, Extreme Networks, Alcatel-Lucent, 3Com, Linksys and more.

Applications

- 40G Ethernet
- Infiniband 4x SDR, DDR, QDR
- Fibre Channel
- Rack to rack connections

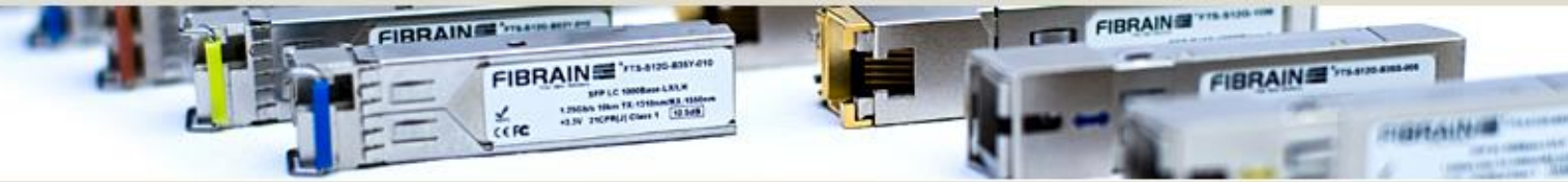

Key features

- MPO/MTP receptacle
- Transmission distance up to 150m*
- VCSEL diode 850nm transmitter array, PIN receiver array
- Throughput up to 40Gb/s
- Fully compliant with QSFP+ MSA SFF-8436
- Hot-Pluggable
- RoHS compliant
- Class 1 laser safety
- Low power dissipation (<3W)
- Metal case for low EMI
- Operating case temperature: 0~70°C

Specification

Supported transmission technology

40G Ethernet, Fibre Channel

Speed supported for Ethernet technology

40Gbps, 10Gbps

Speed supported for Fibre Channel technology

40GFCoE, 10GFCoE

Transmission medium

Multi-mode fiber 50/125µm or 62.5/125µm [on shorter distance]

Transmission distance*

150m

Receptacle type

MPO/MTP

Wavelength

850nm

Output power

-7.5~-1dBm

Receiver sensitivity

-9.5dBm

Power supply voltage

3.3V

Total power consumption

< 1.5W

Operating environment – temperature

0~70°C

Operating environment - humidity

5~95% non-condensing

Dimensions

Compliant with QSFP+ Multi-Source Agreement

* - transmission distance depends on optical link attenuation

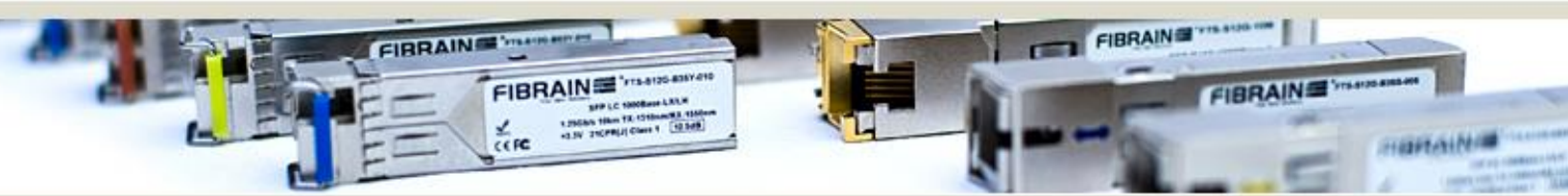

Detailed technical specification

Pin Description

Pin	Name	Function/Description	Notes
1	GND	Transmitter Ground (Common with Receiver Ground)	1
2	Tx2-	Transmitter Inverted Data Input	-
3	Tx2+	Transmitter Non-Inverted Data output	-
4	GND	Transmitter Ground (Common with Receiver Ground)	1
5	Tx4-	Transmitter Inverted Data Input	-
6	Tx4+	Transmitter Non-Inverted Data output	-
7	GND	Transmitter Ground (Common with Receiver Ground)	1
8	ModSelL	Module Select	2
9	ResetL	Module Reset	2
10	VccRx	3.3V Power Supply Receiver	-
11	SCL	2-Wire serial Interface Clock	2
12	SDA	2-Wire serial Interface Data	2
13	GND	Transmitter Ground (Common with Receiver Ground)	1
14	Rx3+	Receiver Non-Inverted Data Output	-
15	Rx3-	Receiver Inverted Data Output	-
16	GND	Transmitter Ground (Common with Receiver Ground)	1
17	Rx1+	Receiver Non-Inverted Data Output	-
18	Rx1-	Receiver Inverted Data Output	-
19	GND	Transmitter Ground (Common with Receiver Ground)	1
20	GND	Transmitter Ground (Common with Receiver Ground)	1
21	Rx2-	Receiver Inverted Data Output	-
22	Rx2+	Receiver Non-Inverted Data Output	-
23	GND	Transmitter Ground (Common with Receiver Ground)	1
24	Rx4-	Receiver Inverted Data Output	1
25	Rx4+	Receiver Non-Inverted Data Output	-
26	GND	Transmitter Ground (Common with Receiver Ground)	1
27	ModPrsl	Module Present	-
28	IntL	Interrupt	2
29	VccTx	3.3V power supply transmitter	-
30	Vcc1	3.3V power supply	-
31	LPMode	Low Power Mode	2
32	GND	Transmitter Ground (Common with Receiver Ground)	1
33	Tx3+	Transmitter Non-Inverted Data Input	-
34	Tx3-	Transmitter Inverted Data Output	-
35	GND	Transmitter Ground (Common with Receiver Ground)	1
36	Tx1+	Transmitter Non-Inverted Data Input	-
37	Tx1-	Transmitter Inverted Data Output	-
38	GND	Transmitter Ground (Common with Receiver Ground)	1

Notes:

1. The module signal grounds are isolated from the module case.
2. This is an open collector/drain output that on the host board requires a 4.7K Ω to 10K Ω pull-up resistor to VccHost.



Electrical parameters

Parameter	Symbol	Min.	Typ.	Max.	Unit	Notes
Transmitter Differential Input Volt	+/-TX_DAT	180		900	mV p-p	1
Receiver Differential Output Volt	+/-RX_DAT	300		850	mV p-p	2
Tx_Disable Input Voltage – Low	V _{IL}	0		0.8	V	
Tx_Disable Input Voltage – High	V _{IH}	2.0		V _{CC}	V	
Tx_Fault Output Voltage – Low	V _{OL}	0		0.8	V	3
Tx_Fault Output Voltage – High	V _{OH}	2.0		V _{CC}	V	3
Rx_LOS Output Voltage- Low	V _{OL}	0		0.8	V	3
Rx_LOS Output Voltage- High	V _{OH}	2.0		V _{CC}	V	3
Throughput	B			40	Gb/s	
Total current requirement				0.35	A	

Transmitter parameters

Parameter	Symbol	Min.	Typ.	Max.	Unit	Notes
Central wavelength	λ_c	840	850	860	nm	
Spectral width	$\Delta\lambda$			0.65	nm	
Launch optical power	P _o	-7.5		-1	dBm	4
Extinction ratio	EX	3			dB	
Dispersion penalty				3.2	dB	
Optical rise/fall time	T _{rise} /T _{fall}			30	ps	5
Eye diagram	Compliant with IEEE802.3-2005 40GBASE-SR4					

Receiver parameters

Parameter	Symbol	Min.	Typ.	Max.	Unit	Notes
Sensitivity	P _{min}			-9.5	dBm	6
Central wavelength	λ_c	840		860	nm	
Receiver overload	P _{MAX}	0			dBm	6,7
RX_LOS Asserted	S _A	-30			dBm	
RX_LOS De-Asserted	S _D			-11	dBm	
RX_LOS Hysteresis	-		3.0		dB	
Optical return loss	ORL	12			dB	

Notes:

- Internally AC coupled and terminated to 100Ω differential load.
- Internally AC coupled, but requires a 100Ω differential termination or internal to Serializer/Deserializer.
- It is open collector/drain output which should be pulled up externally to V_{CC} with a 4.7KΩ-10KΩ resistor on the host board. LOS: logic 0 indicates normal operation; logic 1 indicates no signal detected.
- Optical power is launched into MMF
- 20-80%
- Measured with PRBS 2³¹-1 at test pattern @10.3125Gbps.
- Maximum input power per channel.



Mechanical specification →

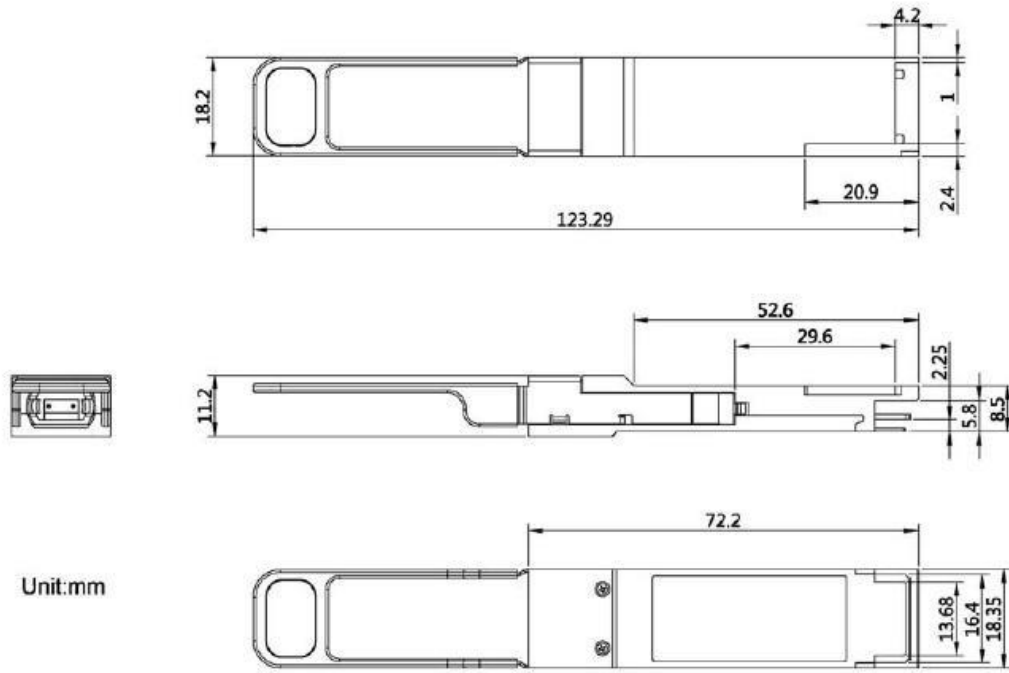

Optical Interface Lanes and Assignment →

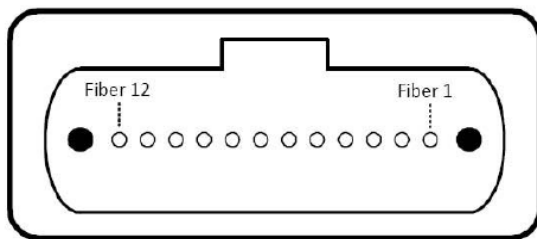

Outside View of the QSFP Module MPO

Fiber No.	Line Assignment
1	RX0
2	RX1
3	RX2
4	RX3
5	Not Used
6	Not Used
7	Not Used
8	Not Used
9	TX3
10	TX2
11	TX1
12	TX0



Recommended environment conditions

Parameter	Symbol	Min	Typ	Max	Unit
Operating Temperature Range	T	0	25	70	°C
Supply Voltage	V _{CC}	3.135	3.3	3.465	V
Relative Humidity	RH	5	-	95	%

Ordering information

FTQ-M4XG-S85L-15MD– 850nm, 150m, multi-mode, LC duplex, **DDMI**, commercial temperature (0~70°C)

For further information regarding host device PCB layout recommendation, power supply requirements, EEPROM memory map, DDMI specification please check:

[SFF-8436 - Technical specification for QSFP transceiver](#)

Fibrain Sp. z o.o. reserves the right to make changes to the products or information contained herein without notice. No liability is assumed as a result of their use or application.

Pictures used for reference only, actual product look may differ. For most actual information please contact technical support via aktywa@fibrain.pl